

JFXL AT 40mm

BACKWASH FILTER

JUDO is engineered to eliminate suspended particles that lead to pitting, corrosion, and blockages, effectively addressing these common problems and safeguarding valuable assets.



JUDO FIMAT JFXL SERIES 40MM JFXL AT: TIMER CONTROL 4HR, 8HR, 24HR, 1WK, 1MNTH

FEATURES

- Manual or fully automatic screen cleaning by timer or pressure differential control
- Extremely efficient screen cleaning ratio of 1:1 using point rotation principle
- Standard 100 micron stainless steel screen, which is silver coated to inhibit bacterial growth
- No interruption to water flow during screen cleaning
- Can be mounted in vertical or horizontal pipe runs
- Relies on pressure not flow for backwash
- Degree of dirt build up can be easily seen through the viewing glass
- Compact
- Minimum installation disruption
- Automatic or Manual Operation
- To suit site and budget
- Quality guaranteed
- German design and manufacture

Freecall 1800 656 771
southlandfiltration.com.au

PLANS/DRAWINGS

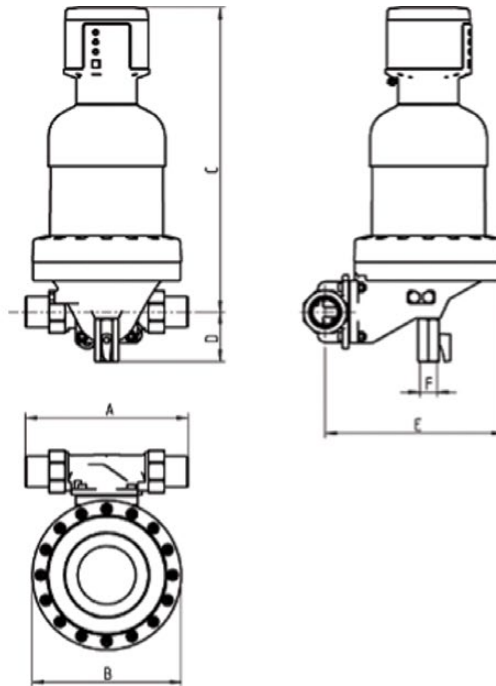

OPERATIONAL REQUIREMENTS

PRODUCT CODE

J8020099

FLOW RATES

Max Flow Rate m³/hour (l/s) 20.0 (5.5)

OPERATING PRESSURES (KPA)

Maximum working pressure 1000

Minimum pressure 200

Minimum outlet pressure N/A

CONNECTIONS

Inlet/Outlet (BPSM) 1 1/2" (40mm)

POWER

Power supply (Watts) 0.5mA

Electrical supply (V/Hz) 230/50 with a 24VAC plug pack

TEMPERATURE

Max temperature 30

WEIGHT (KG)

17

FILTER SURFACE AREA (CM²)

533

BACKWASH

Backwash water volume (Litres) 60-180

Backwash flow rate (l/sec) 0.5 - 1.5

Backwash cycle duration (Sec) 120

MAXIMUM PRESSURE LOSS (KPA) AT MAX FLOW RATE

20kPa

INSTALLED DIMENSIONS (MM)

A Installation length = 252

B Unit Width = 232

C Height above pipe centre = 472

D Height under pipe centre = 76

E Depth to pipe centre = 276

F Backwash outlet = 20

G N/A

Disclaimer. Southland Filtration reserves the right to, at any time change any details of design, specifications and performance figures of any published data.

Freecall 1800 656 771
southlandfiltration.com.au

southland
 FILTRATION

JFXL AT 50mm

BACKWASH FILTER

JUDO is engineered to eliminate suspended particles that lead to pitting, corrosion, and blockages, effectively addressing these common problems and safeguarding valuable assets.



JUDO FIMAT JFXL SERIES 50MM JFXL AT: TIMER CONTROL 4HR, 8HR, 24HR, 1WK, 1MNTH

FEATURES

- Manual or fully automatic screen cleaning by timer or pressure differential control
- Extremely efficient screen cleaning ratio of 1:1 using point rotation principle
- Standard 100 micron stainless steel screen, which is silver coated to inhibit bacterial growth
- No interruption to water flow during screen cleaning
- Can be mounted in vertical or horizontal pipe runs
- Relies on pressure not flow for backwash
- Degree of dirt build up can be easily seen through the viewing glass
- Compact
- Minimum installation disruption
- Automatic or Manual Operation
- To suit site and budget
- Quality guaranteed
- German design and manufacture

Freecall 1800 656 771
southlandfiltration.com.au

PLANS/DRAWINGS

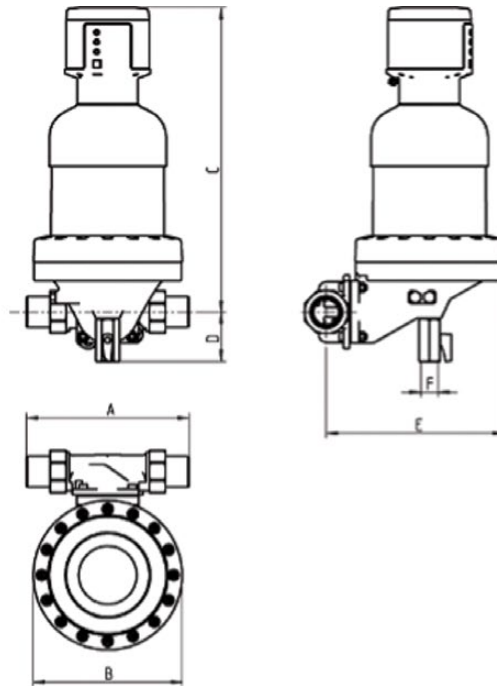

OPERATIONAL REQUIREMENTS

PRODUCT CODE

J8020100

FLOW RATES

Max Flow Rate m³/hour (l/s) 22.0 (6.1)

OPERATING PRESSURES (KPA)

Maximum working pressure 1000

Minimum pressure 200

Minimum outlet pressure N/A

CONNECTIONS

Inlet/Outlet (BPSM) 2" (50mm)

POWER

Power supply (Watts) 0.5mA

Electrical supply (V/Hz) 230/50 with a 24VAC plug pack

TEMPERATURE

Max temperature 30

WEIGHT (KG)

17

FILTER SURFACE AREA (CM²)

533

BACKWASH

Backwash water volume (Litres) 60-180

Backwash flow rate (l/sec) 0.5 - 1.5

Backwash cycle duration (Sec) 120

MAXIMUM PRESSURE LOSS (KPA) AT MAX FLOW RATE

20kPa

INSTALLED DIMENSIONS (MM)

A Installation length = 280

B Unit Width = 232

C Height above pipe centre = 472

D Height under pipe centre = 76

E Depth to pipe centre = 284

F Backwash outlet = 20

G N/A

Disclaimer. Southland Filtration reserves the right to, at any time change any details of design, specifications and performance figures of any published data.

Freecall 1800 656 771
southlandfiltration.com.au

southland
 FILTRATION

JFXL AT VF 40mm

BACKWASH FILTER

JUDO is engineered to eliminate suspended particles that lead to pitting, corrosion, and blockages, effectively addressing these common problems and safeguarding valuable assets.



JUDO FIMAT JFXL SERIES 40MM JFXL AT VF: TIMER CONTROL WITH VOLT FREE CONTACTS

FEATURES

- Manual or fully automatic screen cleaning by timer or pressure differential control
- Extremely efficient screen cleaning ratio of 1:1 using point rotation principle
- Standard 100 micron stainless steel screen, which is silver coated to inhibit bacterial growth
- No interruption to water flow during screen cleaning
- Can be mounted in vertical or horizontal pipe runs
- Relies on pressure not flow for backwash
- Degree of dirt build up can be easily seen through the viewing glass
- Compact
- Minimum installation disruption
- Automatic or Manual Operation
- To suit site and budget
- Quality guaranteed
- German design and manufacture

Freecall 1800 656 771
southlandfiltration.com.au

PLANS/DRAWINGS

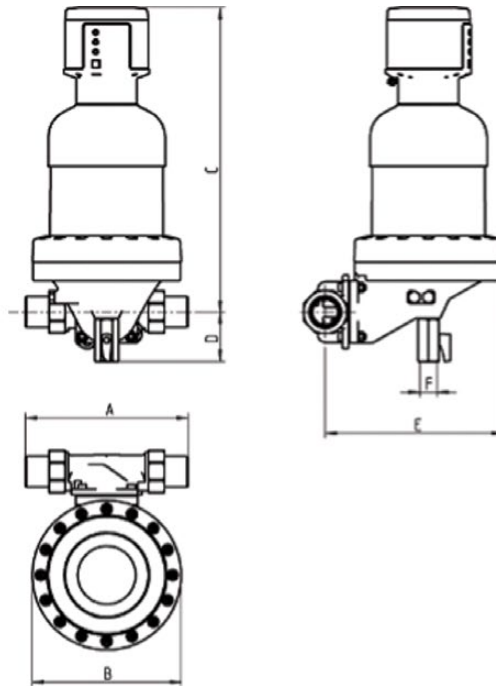

OPERATIONAL REQUIREMENTS

PRODUCT CODE

J8020099 + J0085001

FLOW RATES

Max Flow Rate m³/hour (l/s) 20.0 (5.5)

OPERATING PRESSURES (KPA)

Maximum working pressure 1000

Minimum pressure 200

Minimum outlet pressure N/A

CONNECTIONS

Inlet/Outlet (BPSM) 1 1/2" (40mm)

POWER

Power supply (Watts) 0.5mA

Electrical supply (V/Hz) 230/50 with a 24VAC plug pack

TEMPERATURE

Max temperature 30

WEIGHT (KG)

17

FILTER SURFACE AREA (CM²)

533

BACKWASH

Backwash water volume (Litres) 60-180

Backwash flow rate (l/sec) 0.5 - 1.5

Backwash cycle duration (Sec) 120

MAXIMUM PRESSURE LOSS (KPA) AT MAX FLOW RATE

20kPa

INSTALLED DIMENSIONS (MM)

A Installation length = 252

B Unit Width = 232

C Height above pipe centre = 472

D Height under pipe centre = 76

E Depth to pipe centre = 276

F Backwash outlet = 20

G N/A

Disclaimer. Southland Filtration reserves the right to, at any time change any details of design, specifications and performance figures of any published data.

Freecall 1800 656 771
southlandfiltration.com.au

southland
 FILTRATION

JFXL AT VF 50mm

BACKWASH FILTER

JUDO is engineered to eliminate suspended particles that lead to pitting, corrosion, and blockages, effectively addressing these common problems and safeguarding valuable assets.



JUDO FIMAT JFXL SERIES 50MM JFXL AT VF: TIMER CONTROL WITH VOLT FREE CONTACTS

FEATURES

- Manual or fully automatic screen cleaning by timer or pressure differential control
- Extremely efficient screen cleaning ratio of 1:1 using point rotation principle
- Standard 100 micron stainless steel screen, which is silver coated to inhibit bacterial growth
- No interruption to water flow during screen cleaning
- Can be mounted in vertical or horizontal pipe runs
- Relies on pressure not flow for backwash
- Degree of dirt build up can be easily seen through the viewing glass
- Compact
- Minimum installation disruption
- Automatic or Manual Operation
- To suit site and budget
- Quality guaranteed
- German design and manufacture

Freecall 1800 656 771
southlandfiltration.com.au

PLANS/DRAWINGS

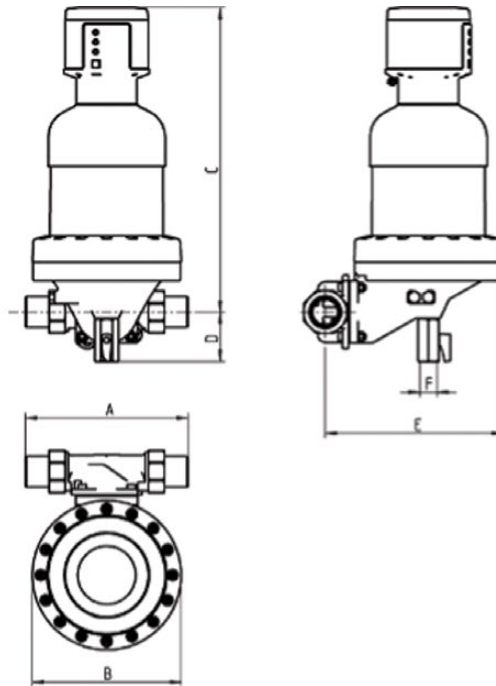

OPERATIONAL REQUIREMENTS

PRODUCT CODE

J8020100 + J0085001

FLOW RATES

Max Flow Rate m³/hour (l/s) 22.0 (6.1)

OPERATING PRESSURES (KPA)

Maximum working pressure 1000

Minimum pressure 200

Minimum outlet pressure N/A

CONNECTIONS

Inlet/Outlet (BPSM) 2" (50mm)

POWER

Power supply (Watts) 0.5mA

Electrical supply (V/Hz) 230/50 with a 24VAC plug pack

TEMPERATURE

Max temperature 30

WEIGHT (KG)

17

FILTER SURFACE AREA (CM²)

533

BACKWASH

Backwash water volume (Litres) 60-180

Backwash flow rate (l/sec) 0.5 - 1.5

Backwash cycle duration (Sec) 120

MAXIMUM PRESSURE LOSS (KPA) AT MAX FLOW RATE

20kPa

INSTALLED DIMENSIONS (MM)

A Installation length = 280

B Unit Width = 232

C Height above pipe centre = 472

D Height under pipe centre = 76

E Depth to pipe centre = 284

F Backwash outlet = 20

G N/A

Disclaimer. Southland Filtration reserves the right to, at any time change any details of design, specifications and performance figures of any published data.

Freecall 1800 656 771
southlandfiltration.com.au

southland
 FILTRATION