

AF2 Series

SCREEN FILTERS

Effortlessly maintain infrastructure with Autofine Self-Cleaning Solution; for hot and cold water, automatic cycles triggered by pressure difference ensure peak performance, saving time and money.



AF2-50, AF2-80

FEATURES

- Flows up to 12.5 L/s
- Pressure differential backwash control
- Control panel with indication lights and volt free contacts
- Low consumption for backwash
- Screen sizes available as detailed below
- 304 Grade stainless steel housing (316L available)
- Min operating pressure: 200kPa
- Max operating pressure: 1,000kPa
- 50mm BSP, 80mm BSP, DN80 flange inlet/outlet
- Backwash counter to monitor number of cleaning cycles performed

PLANS/ DRAWINGS

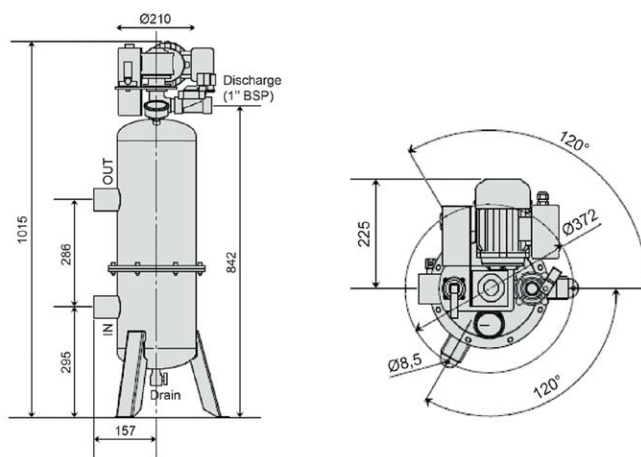

OPERATIONAL REQUIREMENTS

MODEL	PRODUCT CODE	INLET/OUTLET CONNECTION SIZE	MAX FLOW RATE (M3/H)	AVAILABLE FILTRATION DEGREE (µm)							
				0.5	1	5	10	20	40	60, 80, 100, 200	
AF2-50	S25100501	25 BSPM	8	X	X	X	X	X	X	X	X
			12		X	X	X	X	X	X	X
			20			X	X	X	X	X	X
			25					X	X	X	X
AF2-80	S25101002	80 BSPM	35						X	X	
			45							X	

FILTER SURFACE AREA (CM²)

1104

BACKWASH

Backwash water volume (Litres) 8

Backwash cycle duration (Sec) 5

MAXIMUM PRESSURE LOSS (KPA)

50

OPERATING PARAMETERS

Maximum working pressure (kPa) 1000/1600*

Minimum inlet pressure (kPa) 250

Minimum outlet pressure (kPa) 200

Maximum water temperature (°C) 70/90*

POWER

Electrical supply (V/Hz) 240/50

Power rating (Watts) 110

BMS CONNECTIVITY

Alarm signal & Cleaning signal

WEIGHT (KG)

Weight (Empty) (kg) 26

MATERIALS OF CONSTRUCTION

Filter housing SS 304**

Suction arm assembly POM

Solenoid valve (see note) Brass

DP switch (see note) Brass

Filter screen support (see note) SS 316L

Woven Filter screen fabric (3um to 500um) PETP or PA 6.6

Non woven Filter Screen Fabric (0.5um to 2um) Polyester

Seals EPDM

NOTE: Seawater versions are available, using Rilsan coated SS 316L and DP switch and Nylon discharge valve. Fasteners and screen support are Duplex SS. * 90°C units are available ** 316L units are available

Disclaimer. Southland Filtration reserves the right to, at any time change any details of design, specifications and performance figures of any published data.

Freecall 1800 656 771
southlandfiltration.com.au

southland
 FILTRATION